



DELTA PLUS
FROMENT®

THE FALL ARREST GUIDE

مركز البراغي والعدد
BTCO
BOLTS & TOOLS CENTER



INDEX					
Product Reference	Page	Product Reference	Page	Product Reference	Page
AC001	55	BASGAMMA	62	LV502	49
AC002	55	BASGANO	62	LV503	49
AM002	55	CAMELEON	42	LV504	48
AM006	55	DAYAK	50	LV505	48
AM007	51	DESCORD	56	LV506	48
AM009	54	ELARA130	29	LV510	48
AM010	55	ELARA140	27	LV514	48
AM018	54	ELARA150	28	LV515	48
AM020	55	ELARA160	29	LV516	48
AM021	55	ELARA170	28	LV518	49
AM022	54	ELARA190	28	LV519	49
AM025	55	ELARA270	27	LV520	49
AM027	54	ELARA280/320	26	LV521	48
AM030	54	EX021	24	LV522	48
AN003	45	EX030200/400	24	LV523	49
AN006	43	EX118200A/400A	24	LV527	48
AN013	44	EX120	22	LV528	48
AN024/025	47	EX120RL150C	23	LV529	48
AN060	44	EX220	14	LV530	48
AN06300	45	FALLDET	25	LV531	48
AN06310/20/30	45	FENNEC	45	LV532	48
AN066/066A	43	GRANITE	62	LV533	49
AN070	47	GRAPEXXFL	62	LV534	49
AN102A	40	GRAWIXXFL	62	LV535	49
AN102AD	40	H2000/1/E1	19	LV536	49
AN105	40	H2000/2/3/3C	18	LV537	49
AN11010F/T	39	H2000/206	19	LV539	49
AN11023F/T	39	H2000KITS	19	LV543	49
AN115F/T	39	HA091/093	20	LV555	48
AN116F/T	39	HA201	25	MINIBLOC	40
AN11730F/T	39	HA203	25	SPEEDLINE	50
AN141F/T	38	HAR11/12/14	22	SPIDERLINE II	49
AN142F/T	38	HAR12GILJA/NO/OR	23	TC001	56
AN152F/T	38	HAR22/24	14	TC002	56
AN153F/T	38	HAR23	15	TC003	56
AN154F/T	38	HAR23GILNO	15	TC004	56
AN201200XX	36	HAR32	13	TC005	57
AN2013200XXX	37	HAR35	12	TC006	56
AN203200XX	37	HAR35TC	11	TC009	43
AN208150XX	31	HAR36TC	10	TC012	57
AN208200XX	35	HAR46D	17	TC013	60
AN208R	31	JANUS10	20	TC014	60
AN209XX	34	JUGGAMMA	62	TC015	57
AN211200XXX	36	JUGGANO	62	TC016	57
AN218150XXX	31	LDVH	48	TC019	61
AN218200XXX	35	LDVV	47	TC022	61
AN218R	31	LO005200	53	TC025	57
AN219XXX	34	LO007100/150	53	TC029	57
AN230/240	30	LO007150CD	53	TC040	56
AN315/317/319	44	LO030	53	TC044	56
AN401	43	LO031	53	TC102	61
AN410	43	LO032	53	TC103	61
AN420	43	LO047100/150/200	52	TC105	21
AN430	43	LO047150AD	52	TC106	16
AN510	41	LO147150	52	TR003C	58
AN517/518	41	LO147150CDD	52	TR003K	58
AN521	41	LV040	48	TR007F/T	40
AN530	41	LV057	48	TR01730F/T	40
AN801/802	47	LV100	51	TR020	58
ANSI503/510/511/515	16	LV102100/150	51	TR022	58
ANSI516/552	17	LV105	51	TR101	58
ANSI523/537/561	32	LV120G	50	TR102	58
ANSI557/560	33	LV130	50	TRBAG	58
ASCAB	47	LV201	50	WALMB207	21
ASCORD	44	LV500	49	WALTL1200	25

KEY TO PICTOGRAMMS

• INDUSTRIES



CONSTRUCTION/CIVIL ENGINEERING



SECOND WORK/CRAFTMAN



LIGHT INDUSTRY

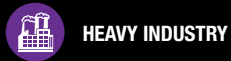

HEAVY INDUSTRY



SERVICES/LOGISTICS



OIL & GAS



MINE



WIND



FACILITY

• FALL ARREST WORK SITUATIONS

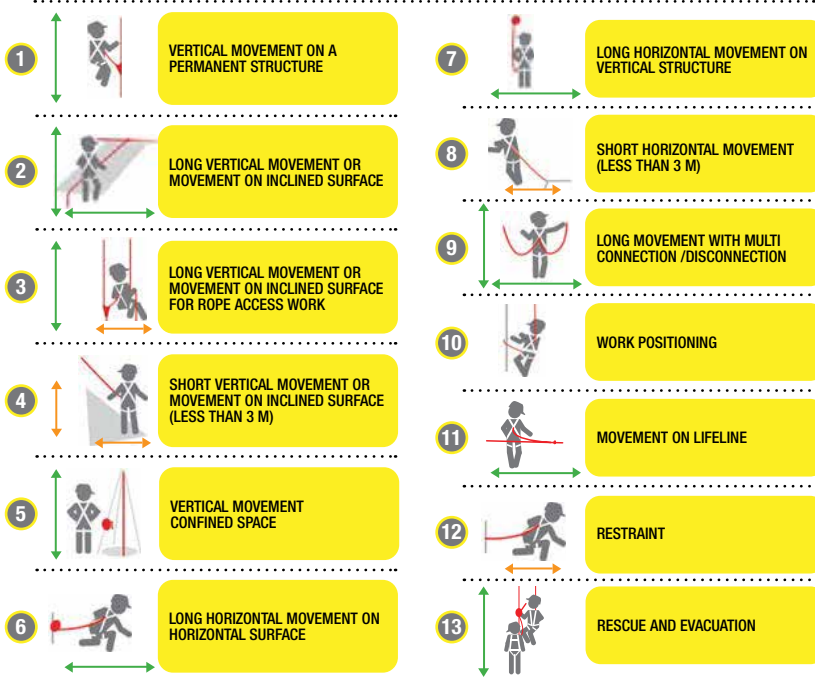
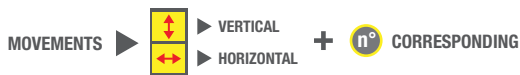

THE DELTA PLUS GROUP IN FIGURES



SHARE OF TURNOVER

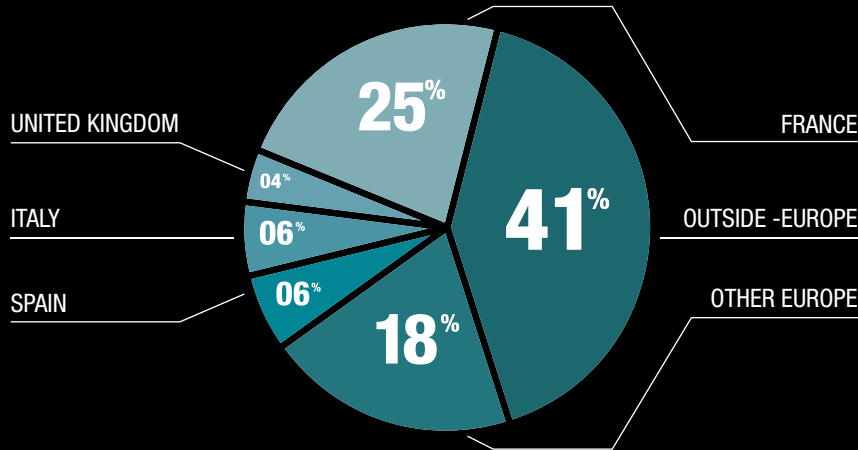

DELTA PLUS

- Date established: 1977
- Designer and manufacturer of PPE
- Listed on the Paris Stock Exchange since 1999
- 7 production sites
- 22 distribution subsidiaries
- 5 logistics platforms
- 1,500 products
- 10,000 customers worldwide
- 1,400 employees

TURNOVER

(in millions of Euro)

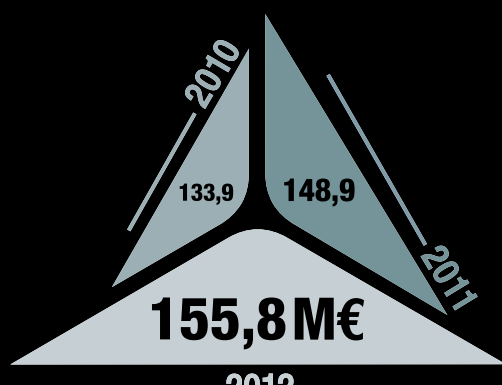

Tel: (+920) 443 54 298
www.boltsandtools.com

HEAD PROTECTION

2 million helmets
2 million pairs of glasses
8 million masks

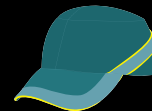

FALL PROTECTION

400,000 systems sold



BODY PROTECTION

4 million work wear items
3 million outdoor wear items
> 1 million rain wear items



HAND PROTECTION

50 million pairs of gloves



FOOT PROTECTION

3 million pairs of shoes



Tel: (+974) 443 54 298
www.boltsandtools.com

Tel: (+974) 443 54 298
www.boltsandtools.com

ALLSAFE COMMITMENTS FOR THE LAST 15 YEARS

QUALITY

ISO 9001:2008 and 11B Certification
CE and ANSI approved products
Strict QC and inspection standards
Stringent internal testing facility
Third party certification upon customer requirement

SERVICE

Reactivity thanks to state of the art production facility
Regional distribution network
Stock availability
Focus on customer satisfaction and on time delivery

EXPERTISE

Professional team
Technical support, training, inspection
Confident approach

VALUE OFFER

Complete fall arrest solution
Range suitable to various industries: Oil & Gas, Construction, Marine
New innovative and ergonomic products
Adjusted quality / price ratio



**ALLSAFE
THE MIDDLE EAST
FALL ARREST
PIONEER**



FALL PROTECTION

HELP WITH CHOICE

Body Support

Fall arrest harnesses p. 10

Fall protection sets p. 26

Fall arresters

Energy absorbing lanyards p. 30

Retractable fall arresters p. 38

Fall arrester on flexible anchorage line p. 42

Fall arrester on flexible/Rigid anchorage line p. 46

Spiderline II p. 48

Anchorage

Anchorage devices p. 50

Lanyards p. 52

Connectors p. 54

Rope access

Rope access work p. 56

Rescue

Fall arrest and rescue confined space p. 58

Rescue and evacuation p. 60

Technical information





FALL PROTECTION SYSTEMS

FALL ARREST



FULL BODY HARNESS



FALL ARREST



ANCHORAGE

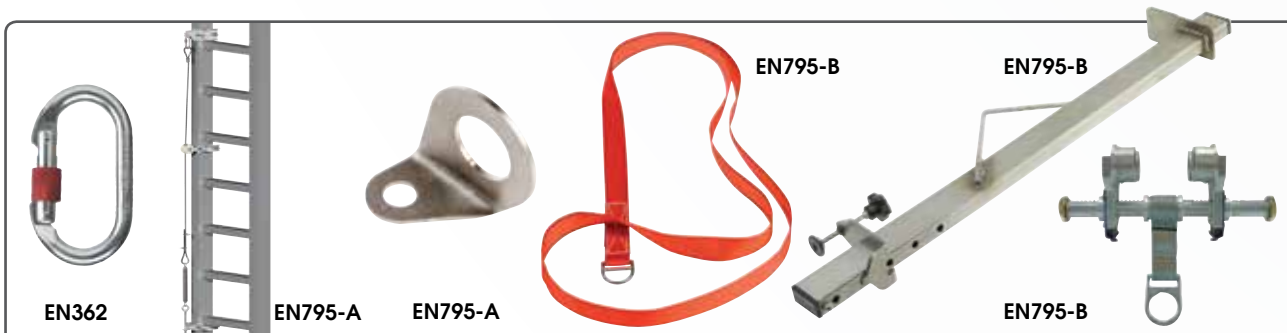

HELP WITH CHOICE

RESCUE AND SUSPENSION HARNESSSES



RESTRAINT SYSTEMS

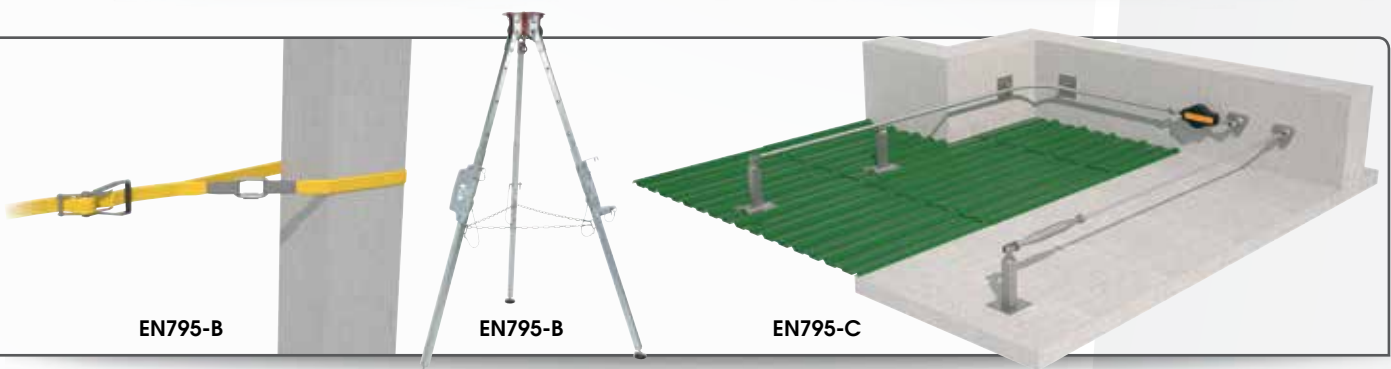
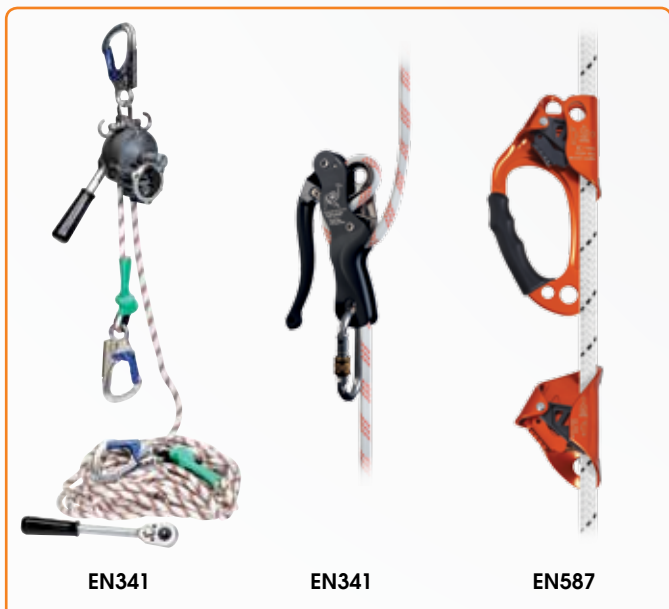



HARNESSES

CHOOSING YOUR HARNESS

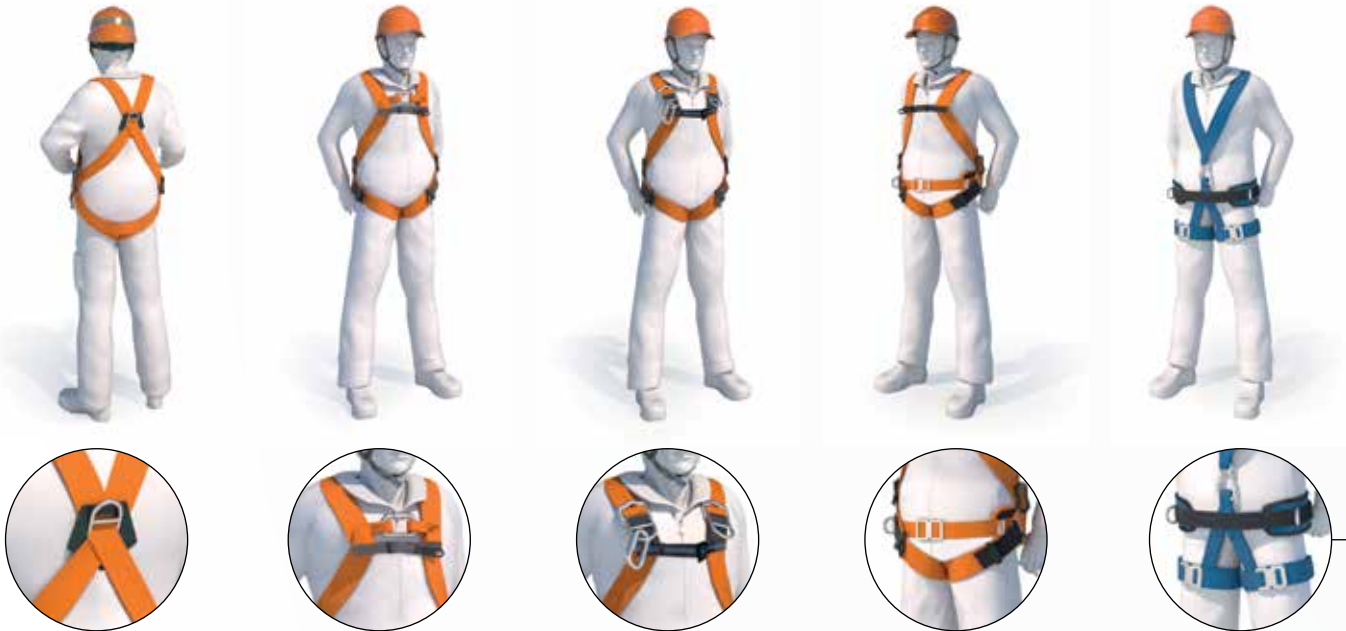

CHOOSING YOUR SIZE

REF	SIZES	1	2	3	4
GT	S-M-L	<195 cm	<110 cm	<115 cm	<65 cm
XX	XL-XXL	>190 cm	>105 cm	>110 cm	>60 cm

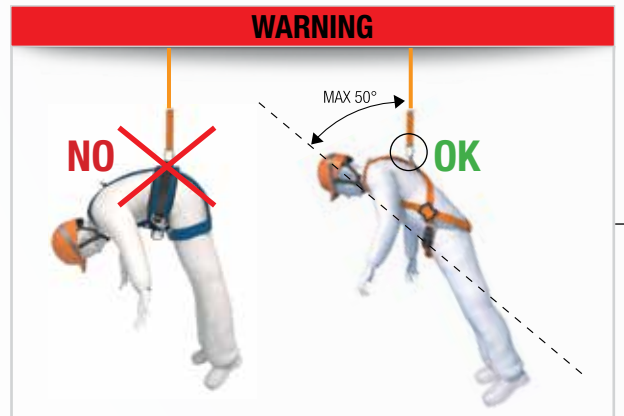
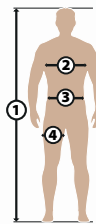

DONNING A HARNESS



HELP WITH CHOICE

FALL ARREST

SELF RETRACTABLE FALL ARRESTER



TEMPORARY AND PERMANENT LIFELINES



ENERGY ABSORBER

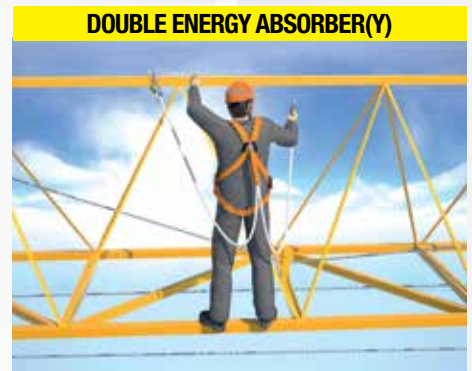

CLEARANCE

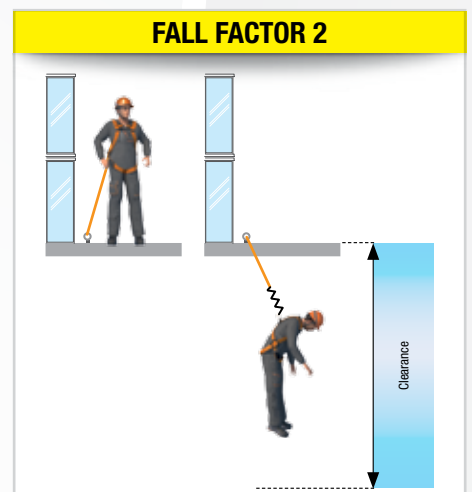
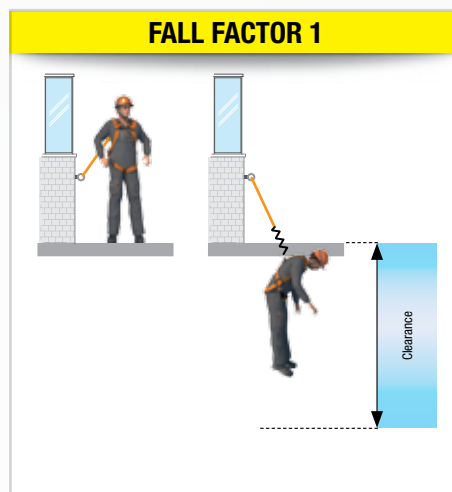
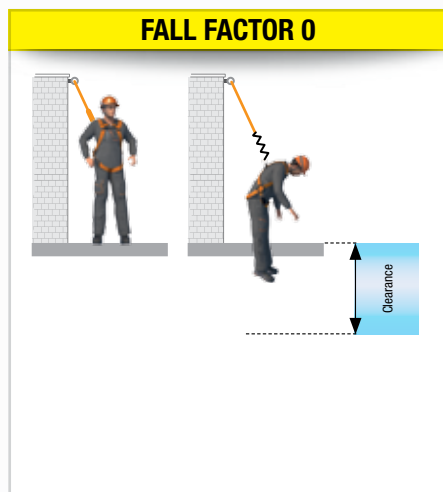



AFTER SALES SERVICE

MANDATORY GENERAL ANNUAL INSPECTION

EN365

Instructions for periodic inspections shall include among other things:

- A recommendation for the frequency of periodic inspections, taking into account factors such as regulation, the type of equipment, frequency of use, and environmental conditions. This recommendation shall include a clause stating that the periodic

inspection should be conducted at least annually;

- A warning to emphasise that periodic inspections should be carried out by a competent person in strict compliance with the manufacturer periodic inspection procedures.



Up to 10 years from the date of manufacture or 7 years from the usage date for textile PPE

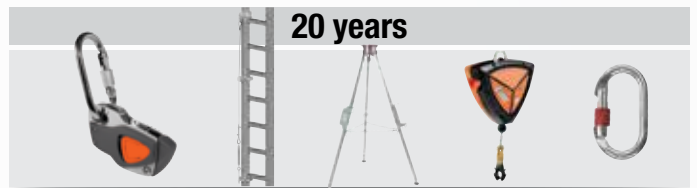

Up to 20 years from the date of manufacture for metallic PPE

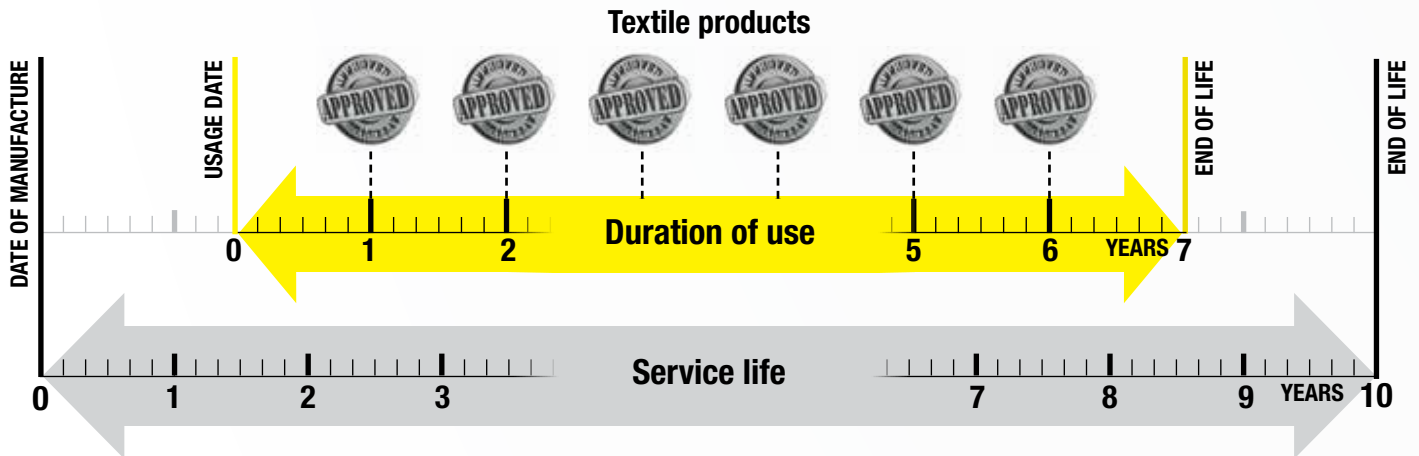

VISUAL INSPECTION FOR:

Harnesses, belts, lanyards, ropes, energy absorbers, non removable reels (e.g. AN102), connectors, components of our kits (except ELARA270), temporary anchors (tripod, LV201 ...)

MECHANICAL INSPECTION FOR:

Removable reels, rescue equipment (e.g. TC013)



HOW TO SCHEDULE THE ANNUAL INSPECTION

Label on the product with the next date



Register on the site www.deltaplus.eu



Or:

- Schedule by the user
- Schedule by the employer
- Label on the storage area of the product
- Use the following organisations for the scheduling:
 - the dealer
 - the Delta Plus manufacturer
 - the Service Center



EN365

USERS: «It is essential that staff are **trained**, that their competence is controlled and they have written instructions enabling them to choose, use, maintain and periodically revise the PPE or other equipment.»

AUDITORS: «A competent person has to be trained by the manufacturer (i.e.) significant safety related knowledge necessary for the disassembly, reassembly, or evaluation of PPE or other equipment.»

OUR TRAINING OFFER:

12 training modules adapted to different audiences: users, distributors, technical inspection services and repair.

TRAINING IS INDISPENSABLE:

It allows:

- Awareness of work at height
- Analysis of risk situations
- Securing workstations
- Finding protection solutions
- Providing more productivity
- Providing technical expertise in inspection, maintenance and repair of products



LOCAL AFTER SALES SERVICES

Network of service centres

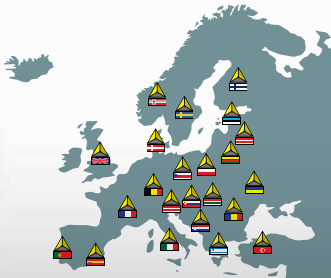

Info on www.deltaplus.eu



Training centres www.dpgtraining.com



BODY SUPPORT

WAILY HAR36TC

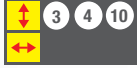

comfort pad

Ideal working position thanks to the semi rigid harness seat

Article	Ref./Colours	Standard	Description	Sizes/Length		
WAILY HAR36TC	HAR36TCGT	CE EN361 EN358	Harness with belt and work harness seat: 2 fall arrester anchorage points (back - front). Positioning belt with thermoformed back and legs. 2 work positioning attachment points (lateral). Harness seat with two suspension points. 5 adjustable buckles of which 3 are automatic	S/M/L	2,4 kg	x5
	HAR36TCXX			XL/XXL		

FALL ARREST AND SUSPENSION HARNESES

Most of our products have been tested with a mass constraint greater than 40% to 50% of the normative requirements (140 kg or 150 kg). Find this information in the technical specifications of our products.

GALAGO HAR35TC



Article	Ref./Colours	Standard	Description	Sizes/Length		
GALAGO HAR35TC	HAR35TCGT	EN361 EN358 EN813	Two colour harness with belt: 2 fall arrester anchorage points (back - front). Positioning belt with thermoformed back and shorts. 2 work positioning attachment points (lateral). 1 suspension point. 8 adjustable buckles. 1 carabiner.	S/M/L	1,9 kg	x5
	HAR35TCXX			XL/XXL		



BODY SUPPORT

EOLIEN HAR35



Soft padding on the shoulders and straps on the legs
Removable back protector

Fall indicator

Rotation 120°
2 accessory attachment holders incorporated into the belt

Pocket for phone or fall detector carrier

Article	Ref./Colours	Standard	Description	Sizes/Length		
EOLIEN HAR35	HAR35GT	CE EN361 EN358	Two colour harness with positioning belt. 3 fall arrester attachment points (back- front right side - front left side). 4 adjustable buckles in light alloy. 2 automatic buckles. Positioning belt with thermoformed back closed with wide Velcro for more comfort. 120° rotation. 2 lateral anchorage points. 1 adjustment loop. Sponge back lining.	S/M/L	2 kg	x5
	HAR35XX			XL/XXL		

FALL ARREST HARNESES

Most of our products have been tested with a mass constraint greater than 40% to 50% of the normative requirements (140 kg or 150 kg). Find this information in the technical specifications of our products.

ANATOM HAR32



Soft padding on the shoulders and straps on the legs

Fall indicator

Pocket for phone or fall detector carrier

Article	Ref./Colours	Standard	Description	Sizes/Length		
ANATOM HAR32	HAR32GT	CE EN361	Two colour harness. 2 fall arrester anchorage points (back - front). 8 adjustable buckles.	S/M/L	1,4 kg	x5
	HAR32XX			XL/XXL		



BODY SUPPORT

HAR24



"Riplight System II®"



Fall indicator

Rotation 120°
2 accessory attachment holders incorporated into the belt

Article	Ref./Colours	Standard	Description	Sizes/Length	Weight	Quantity
HAR24	HAR24GT	CE EN361 EN358	Harness with extensible "Riplight System II®" patented waves. 2 fall arrester anchorage points (back - front). 4 adjustable buckles with positioning belt at 120° rotation. Large thermoformed back with sponge lining. 2 lateral anchorage points for work positioning.	S/M/L	1,8 kg	x5

HAR22



"Riplight System II®"



EX220



Article	Ref./Colours	Standard	Description	Sizes/Length	Weight	Quantity
HAR22	HAR22GT	CE EN361	Elasticated harness with extensible "Riplight System II®" patented waves. 2 fall arrester anchorage points (back - front). 4 adjustable buckles.	S/M/L	1 kg	x5
EX220	EX220XX EX220GT	EN358	Positioning belt with thermoformed back closed with wide Velcro for more comfort. 120° rotation. 2 lateral anchorage points. 1 adjustment loop. Sponge back lining.	XL/XXL S/M/L	0,8 kg	

FALL ARREST HARNESES

Most of our products have been tested with a mass constraint greater than 40% to 50% of the normative requirements (140 kg or 150 kg). Find this information in the technical specifications of our products.

HAR23GILNO



"Riplight System II®"

Fall indicator

Article	Ref./Colours	Standard	Description	Sizes/Length	Weight	Quantity
HAR23GILNO	HAR23GILNOGT	CE EN361	Extensible harness with work vest not removable : Harness (Ref. HAR23). Vest: Polyester, Cordura® and 3D knitting. Zip closure. 2 zip pockets. HV retro-reflective side bands. Size adjustable with side cords.	S/M/L	1,8 kg	x5

HAR23



"Riplight System II®"

Fall indicator

Article	Ref./Colours	Standard	Description	Sizes/Length	Weight	Quantity
HAR23	HAR23GT	CE EN361	Elasticated harness with extensible "Riplight System II®" patented waves. 3 fall arrester attachment points (back- right front side - left front side). 4 adjustable buckles.	S/M/L	1,3 kg	x5



BODY SUPPORT

ANSI503



D-Ring extension

Fall indicator

Tongue buckle adjustment



ANSI515



Shoulder D-Ring for entry and retrieval from confined space

Fall indicator



TC106



Article	Ref./Colours	Standard	Description	Sizes/Length	Weight	Quantity
ANSI503	ANSI503	ANSI Z359.1	Full body harness for Oil & Gas industry with one rear anchorage provided with 0.3m extension lanyard. Comfortable workpositioning belt with two side attachments and one rear attachment for restrain.	Standard	2,8 kg	x5
ANSI515	ANSI515	ANSI Z359.1	Full body harness with two anchorage points and four points of adjustment. Two D-rings on either side for work positioning with back support. Two shoulder D-rings for rescue operation.	Standard	2,2 kg	x10
SPREADER LANYARD	TC106		Spreader lanyard for vertical movement and rescue operations with a spread distance of 400mm.	400mm	0,8 kg	x1

ANSI510



Fall indicator

Extended loop on adjustable chest strap for unused leg of the lanyard.



ANSI511



Extended loop on adjustable chest strap for unused leg of the lanyard.

Fall indicator



Article	Ref./Colours	Standard	Description	Sizes/Length	Weight	Quantity
ANSI510	ANSI510	ANSI Z359.1	Full body harness with two anchorage points and two points of adjustment. Two D-rings on either side for work positioning.	Standard	1,1 kg	x10
ANSI511	ANSI511	ANSI Z359.1	Full body harness with one anchorage points and five points of adjustment. Sliders for chest strap.	Standard	1,1 kg	x10

FALL ARREST HARNESSSES

Most of our products have been tested with a mass constraint greater than 40% to 50% of the normative requirements (140 kg or 150 kg). Find this information in the technical specifications of our products.

ANSI516



Quick connect buckles

ANSI552



Extended loop on adjustable chest strap for unused leg of the lanyard

Fall indicator

Article	Ref./Colours	Standard	Description	Sizes/Length	Weight	Quantity
ANSI516	ANSI516	ANSI Z359.1	KEVLAR full body harness with two anchorage points and four points of adjustment. Two D-rings on either side for work positioning with back support. Quick lock buckles for fast usage.	Standard	1,9 kg	x10
ANSI552	ANSI552	ANSI Z359.1	Di-electric full body harness with two anchorage points and five points of adjustment. Two D-rings on either side for work positioning with wide and comfortable back support. Tool hanging loops.	Standard	1,8 kg	x5

HAR46D



Positioning belt provides extra comfort while positioning next to drilling pipe.

D-Ring extension

Thermoformed back pad with back D-Ring

Article	Ref./Colours	Standard	Description	Sizes/Length	Weight	Quantity
HAR46D	HAR46D	CE EN361 EN358	DERRICK harness with one rear anchorage point provide with 0.5m extension lanyard. Comfortable workpositioning belt with two side attachments and one rear attachment for restraint. Thigh strap with comfortable pads. Automatic aluminized buckle for easy donning. Removable front belt with two attachment for monkey board operations.	Standard	2,9 kg	x1



BODY SUPPORT

H2000/3



Extended loop on adjustable chest strap for unused leg of the lanyard.



Wide back pad for better work position and comfort.

Seven ways adjustable

Article	Ref./Colours	Standard	Description	Sizes/Length		
H2000/3	H2000/3	CE EN361 EN358	Full body harness with one anchorage point and six points of adjustment. Sliders for chest strap with tool hangers. Incorporated with a comfortable belt for workpositioning having two side attachment and one point of adjustment.	Standard	1,6 kg	x5

H2000/3C

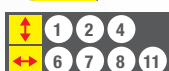

Four way adjustable



H2000/2



Extended loop on adjustable chest strap for unused leg of the lanyard

Four way adjustable



Article	Ref./Colours	Standard	Description	Sizes/Length		
H2000/3C	H2000/3C	CE EN361	Full body harness with three anchorage points and four points of adjustment. The two front anchorages are on either side of the chest for suitable vertical application.	Standard / Large	1,4 kg	x5
H2000/2	H2000/2	CE EN361	Full body harness with two anchorage points and six points of adjustment. Sliders for chest strap with tool hangers.	Standard	1,3 kg	

FALL ARREST HARNESSSES

Most of our products have been tested with a mass constraint greater than 40% to 50% of the normative requirements (140 kg or 150 kg). Find this information in the technical specifications of our products.

H2000/1



Extended loop on adjustable chest strap for unused leg of the lanyard.



Six way adjustable

Article	Ref./Colours	Standard	Description	Sizes/Length	Weight	Quantity
H2000/1	H2000/1	CE EN361	Full body harness with one anchorage points and six points of adjustment. Sliders for chest strap with tool hangers.	Standard	1,2 kg	x5
H20001MFBKIT1	H20001MFBKIT1		H20001MFB + AN209CD	Standard	1,95 kg	x10
H20001MFBKIT2	H20001MFBKIT2		H20001MFB + AN219CDD	Standard	2,52 kg	
H20001MFBKIT3	H20001MFBKIT3		H20001MFB + L0018150M	Standard	1,34 kg	

H2000/E1



Two way adjustable



H2000/206



Wide back pad for better work position and comfort



Article	Ref./Colours	Standard	Description	Sizes/Length	Weight	Quantity
H2000/E1	H2000/E1	CE EN361	Full body harness with one anchorage points and two points of adjustment.	Standard	0,8 kg	x5
H2000E1MFBKIT1	H2000E1MFBKIT1		H2000E1MFB + AN209CD	Standard	1,6 kg	x10
H2000E1MFBKIT2	H2000E1MFBKIT2		H2000E1MFB + AN219CDD	Standard	2,17 kg	
H2000E1MFBKIT3	H2000E1MFBKIT3		H2000E1MFB + L0018150M	Standard	1 kg	
H2000/206	H2000/206	CE EN358	Comfortable work positioning belt with two side attachment points. Can also be used for restraint with suitable lanyard.	Standard	0,6 kg	x10



BODY SUPPORT

HA093



Riplight I system on webbing



Light alloy buckles

Fast buckles

Article	Ref./Colours	Standard	Description	Sizes/Length	Weight	Quantity
HA093	HA093	CE EN361 EN358	RIPLIGHT full body harness with two anchorage points and with a work positioning belt . The extendable riplight system makes the harness comfortable in all working position. All metal parts are made of light alloy.	Standard / Large	1,4 kg	x5

HA091



Riplight I system on webbing

Light alloy buckles

Fast buckles



JANUS10



Article	Ref./Colours	Standard	Description	Sizes/Length	Weight	Quantity
HA091	HA091	CE EN361	RIPLIGHT full body harness with two anchorage points . The extendable riplight system makes the harness comfortable in all working position. All metal parts are made of light alloy.	Standard / Large	1,0 kg	x5
JANUS10	JANUS10	CE EN361	RIPLIGHT full body harness with two anchorage points . The extendable riplight system makes the harness comfortable in all working position. All metal parts are made of light alloy.	Standard / Large	1,0 kg	x5

FALL ARREST HARNESSSES

Most of our products have been tested with a mass constraint greater than 40% to 50% of the normative requirements (140 kg or 150 kg). Find this information in the technical specifications of our products.

BOSUN SEAT



Additional D-Rings on seat board for accessories



Adjustable foot rest

Article	Ref./Colours	Standard	Description	Sizes/Length	Weight	Quantity
BOSUN SEAT	TC105		Comfortable Bosun seat for vertical movement . Length adjustable foot rest for better stability. Tool hanging D-rings on both sides.	Standard	2,2 kg	x1

MINER'S BELT



Retro reflective tapes on belt.



Rear D-Ring

Padded belt to accommodate battery pack and self rescuer.

Article	Ref./Colours	Standard	Description	Sizes/Length	Weight	Quantity
MINER'S BELT	WALMB207		Restraint belt with shoulder strap for mining activities. Two heavy duty tool/battery holders on both sides.	Standard / Large	0,9 kg	x5



BODY SUPPORT

Article	Ref./Colours	Standard	Description		
HAR14 	HAR14MFB	CE EN361 EN358	2 fall arrester anchorage point harness (back - front). 2 adjustment loops. 2 adjustable lateral plates. Positioning belt with broad thermoformed back. Sponge lining. 2 anchorage points for work positioning.	1,1 kg	x5
	HAR14XX				
HAR12 	HAR12MFB	CE EN361	2 fall arrester anchorage point harness (back - front). 2 adjustment loops.	0,7 kg	x5
	HAR12XX				
HAR11 	HAR11MFB	CE EN361	1 fall arrester anchorage point harness (back). 2 adjustment loops.	0,6 kg	x5
	HAR11XX				
EX120 	EX120	CE EN358	Positioning belt with thermoformed back. 2 lateral anchorage points for work positioning. 1 adjustment loop. Sponge back lining.	0,4 kg	x10

FALL ARREST HARNESSES

Most of our products have been tested with a mass constraint greater than 40% to 50% of the normative requirements (140 kg or 150 kg). Find this information in the technical specifications of our products.

Article	Ref./Colours	Standard	Description		
HAR12GILNO 	HAR12GILNOGT	CE EN361	Harness with work vest not removable: Harness (Ref. HAR12). Vest: 65% polyester 35% cotton integrated. Mesh lining 100% polyester mesh netting. Zip closure. 2 pockets. Adjustable size via 3 in 1 multi zip.   	1,2 kg	x10
	HAR12GILNOXX				
HAR12GILJA 	HAR12GILJAGT	CE EN361 EN471 2.2	Harness with high visibility vest not removable: Harness (Ref. HAR12). Vest: 65% polyester 35% cotton integrated. Sewn retro-reflective tape. Polyester mesh lining. Zip closure. 5 pockets including 1 phone pocket. Badge holder place. Adjustable size via 3 in 1 multi zip.   	1,2 kg	x10
	HAR12GILJAXX				
HAR12GILOR 	HAR12GILORGT	CE EN361 EN471 2.2	Harness with high visibility vest not removable: Harness (Ref. HAR12). Vest: 65% polyester 35% cotton integrated. Sewn retro-reflective tape. Polyester mesh lining. Zip closure. 5 pockets including 1 phone pocket. Badge holder place. Adjustable size via 3 in 1 multi zip.   	1,2 kg	x10
	HAR12GILORXX				
EX120LO 	EX120LO150C	CE EN358	Positioning belt with thermoformed back. 2 lateral anchorage points for work positioning. 1 adjustment loop. Sponge back lining. 1.5m rope lanyard and karabiner.   	0,5 kg	x10



ANCHORAGE / WORK SUPPORT

EX030200



Double safety opening: installation without disconnecting from the harness

Opening with one hand

Fall indicator and non-inverting device

Article	Ref./Colours	Standard	Description	Sizes/Length	Person	Box
EX030200	EX030200	CE EN358 EN12841 EN353-2	3 multi function products in 1: Sliding fall arrest on braided rope anchorage line ϕ 10.5 mm - Stopper on rope - Lanyard tensioner equipped with a rope and 1 AM002 carabiner. The fall arrest device slides on its anchorage line and in case of a fall, automatically locks and stops the fall of the user. The rope's adjusting device used in the safety bracket (type A) accompanies the user during his changes of position and locks under the action of a static or dynamic load. The ascension device on its work support, locks under the action of a load in one direction and slides freely in the opposite direction (type B). The positioning device allows adjustment of the distance between the operator (with work positioning belt) and the structure. Lanyard: Braided rope ϕ 10.5 mm with manufactured ends. Hook with automatic lock.	0.20 to 2 m	1,2 kg	x5
EX030400	EX030400			0.20 to 4 m	1,4 kg	

EX118200A



Recommended accessory for the proper use of this product: 1 AM002 connector



EX021



Article	Ref./Colours	Standard	Description	Sizes/Length	Person	Box
EX118200A	EX118200A	CE EN358	Adjustable work positioning lanyard via stainless steel tensioner. Adjustable length. Stranded rope ϕ 14 mm equipped with a wear indicator. Thimble loop. Splice protection. Protective sheath. 1 hook.	0.20 to 2 m	0,9 kg	x5
EX118400A	EX118400A			0.20 to 4 m	1,1 kg	
EX021	EX021		Adjustable work positioning lanyard via reducer. Adjustable length. Stranded rope ϕ 12 mm. Protective sheath on the splices.	1.10 to 2 m	0,3 kg	x15

HA203

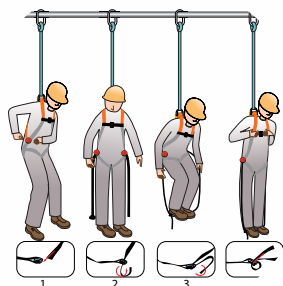
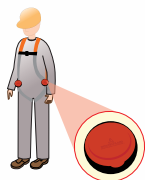

WALTL1200



Article	Ref./Colours	Description	Sizes/Length	Weight	Quantity
HA203	HA203	Pair of straps enabling blood circulation in the legs after a fall while waiting for help. Adjustable for any type of harness by positioning on the side straps. Ease and speed of implementation. Carrying case.		0,3 kg	x10
WALTL1200	WALTL1200	Extensible Tool Hanging Lanyard with a capacity of 2kg.	1.2m	0,06 kg	x5

RIPLIGHT 2 HA201



FALDET



Article	Ref./Colours	Description	Weight	Quantity
RIPLIGHT 2 HA201	HA201	RIPLIGHT SYSTEM II® gives elasticity to your harness by removing the stress points. "Clips" easily on our harness straps. For optimum comfort, it is recommended to use three pairs of expandable waves. Sold in pairs.	0,03 kg	x1
FALDET	FALDET	Fall detector equipped: • with an accelerometer to detect the fall. It can be put in the pocket or, through its external handles, be attached to a belt. • with a button to call for help. No on / off button: It turns ON when it is in motion, and goes into OFF mode after 20 minutes of inactivity. Sold together as they work as a together.	0,04 kg	x1



ELARA320

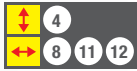

Storage bag



Article	Ref./Colours	Standard	Description	Sizes/Length	Weight	Quantity
ELARA320	ELARA320	CE EN362 EN361 EN355 EN358	POSITIONNING & SCAFFOLDING - ready for use fall arrest kit: 2 fall arrester anchorage point harness (back - front). 2 adjustment loops. 2 adjustable side plates. Positioning belt (Ref. HAR14). Adjustable work positioning lanyard via reducer. Length of 1.1 to 2 m. Stranded rope Ø 12 mm (Ref. EX021). Fall arrester with energy absorber in double stranded rope (Y) Ø 12mm. Length 2 m. 1 AM002 carabiner and 2 AM022 hooks (Ref. AN211200CDD) 2 connectors AM002.	S/M/L	3,6 kg	x5

ELARA280



Storage bag



Article	Ref./Colours	Standard	Description	Sizes/Length	Weight	Quantity
ELARA280	ELARA280	CE EN362 EN361 EN355	SCAFFOLDING - ready for use fall arrest kit: 2 fall arrester anchorage point harness (back - front). 2 adjustment loops. 2 adjustable side plates. (Ref. HAR12). Fall arrester with energy absorber in double stranded rope (Y) Ø 12mm. Length 2 m. 1 AM002 carabiner and 2 AM022 hooks (Ref. AN211200CDD)	S/M/L	2,8 kg	x5

FALL PROTECTION SETS

Most of our products have been tested with a mass constraint greater than 40% to 50% of the normative requirements (140 kg or 150 kg). Find this information in the technical specifications of our products.

ELARA270



Article	Ref./Colours	Standard	Description	Sizes/Length	Weight	Quantity
ELARA270	ELARA270	CE EN362 EN361 EN360 EN354 EN795-B	VERTICAL & HORIZONTAL 10 M - Fall arrester kit ready for use: 2 fall arrester anchorage point harness (back - front). 2 adjustment loops. 2 adjustable side plates. (Ref. HAR12). Self retractable fall arrester with steel strap. Length 10 m. Plastic housing. 1 automatic swivel connector and fall indicator AM016 (Ref. AN123T). Lanyard and anchorage point in tubular strap, length 2 m (Ref. L0030). 2 connectors AM002.	S/M/L	8,5 kg	x1

ELARA140



Storage bag



Article	Ref./Colours	Standard	Description	Sizes/Length	Weight	Quantity
ELARA140	ELARA140GT	CE EN362 EN361 EN360	VERTICAL & HORIZONTAL 2.50 M - Fall arrester kit ready for use: 2 fall arrester anchorage point harness (back - front). 2 adjustment loops. 2 adjustable side plates. (Ref. HAR12). Self retractable fall arrester with 46 mm strap with energy absorber. Protection housing. 1 connector AM002 (Ref. AN102). 1 connector AM002.	S/M/L	2,1 kg	x5
	ELARA140XX			XL/XXL		



ELARA170

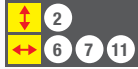

Storage bag



Article	Ref./Colours	Standard	Description	Sizes/Length	Weight	Quantity
ELARA170	ELARA170GT	EN362 EN361 EN353-2	ROOF - ready for use fall arrester kit: 2 fall arrester anchorage point harness (back - front). 2 adjustment loops. 2 adjustable side plates. (Ref. HAR12). Sliding non opening fall arrester set with fall indicator on stranded rope anchorage line Ø 12 mm, length 20 m. (Ref. AN063/10). 2 connectors AM002.	S/M/L	3,3 kg	x5
	ELARA170XX			XL/XXL		
ELARA150	ELARA150GT	EN362 EN361 EN353-2	ROOF - ready for use fall arrester kit: 2 fall arrester anchorage point harness (back - front). 2 adjustment loops. 2 adjustable side plates. (Ref. HAR12). Sliding non opening fall arrester set with fall indicator on stranded rope anchorage line Ø 12 mm, length 10 m. (Ref. AN063/10). 2 connectors AM002.	S/M/L	2,4 kg	x5
	ELARA150XX					

ELARA190



Storage bag

Article	Ref./Colours	Standard	Description	Sizes/Length	Weight	Quantity
ELARA190	ELARA190GT	EN362 EN361 EN355	SCAFFOLDING - ready for use fall arrester kit: 2 fall arrester anchorage point harness (back - front). 2 adjustment loops. 2 adjustable side plates. (Ref. HAR12). Fall arrest with energy absorber with lanyard strap, length 2 m, equipped with 1 connector AM002 and 1 AM022 hook (Ref. AN203200CD).	S/M/L	1,8 kg	x5
	ELARA190XX			XL/XXL		

FALL PROTECTION SETS

Most of our products have been tested with a mass constraint greater than 40% to 50% of the normative requirements (140 kg or 150 kg). Find this information in the technical specifications of our products.

ELARA130



RESTRAINT KIT

Storage bag

Article	Ref./Colours	Standard	Description	Sizes/Length	Weight	Quantity
ELARA130	ELARA130	CE EN362 EN361 EN354	RESTRAINT - ready for use kit: 1 fall arrestER anchorage point harness (back). 2 adjustment loops, 2 adjustable side plates with lanyard in irremovable stranded rope Ø 12 mm. Length 1.50 m. 1 connector AM002.	S/M/L	1,3 kg	x5

ELARA160



Storage bag

Article	Ref./Colours	Standard	Description	Sizes/Length	Weight	Quantity
ELARA160	ELARA160	CE EN362 EN361 EN355	CLASSIC - ready for use fall arrest kit: 1 fall arrestER anchorage point harness (back). Two adjustment loops, 2 adjustable side plates with fall arrestER with not removable energy absorber in stranded rope Ø 12mm, length 2 m. 1 carabiner AM002.	S/M/L	1,5 kg	x5



FALL ARRESTERS







AN240CDD



Energy absorber in woven strap with integrated crumple on the lanyard



Reduced resting length limits discomfort to the operator and the risk of stumbling

Protective sheath on loops to reduce wear caused by the friction of connectors

Article	Ref./Colours	Standard	Description	Connector 1	Connector 2	Sizes/Length	Person	Box
AN240CDD				1 x  AM002	2 x  AM022			
AN240ADD	AN240	CE EN355	Fall arrester with extensible energy absorber in double woven webbing (Y) lanyard. Retracted length: 1.40m. Stretched length: 2.0m.	1 x  AM010	2 x  AM022	2m	2,1 kg	x5
AN240BDD				1 x  AM025	2 x  AM022			

AN230CD



Article	Ref./Colours	Standard	Description	Connector 1	Connector 2	Sizes/Length	Person	Box
AN230CD	AN230	CE EN355	Fall arrester with energy absorber in woven webbing with integrated crumple on the lanyard. Retracted length: 1.40 m. Stretched length: 2 m. 1 carabiner AM002. 1 hook AM022.	1 x  AM002	1 x  AM022	1.40 to 2 m	1,0 kg	x5

ENERGY ABSORBING LANYARDS

AN218150CCC



AN208150CC



Article	Ref./Colours	Standard	Description	Connector 1	Connector 2	Sizes/Length	Weight	Quantity
AN218150CCC	AN218150CCC	CE EN355	Fall arrester with energy absorber in double braided rope (Y) Ø 10.5 mm. Thimble loops.	1 x AM002	2 x AM002	1.50 m	1,2 kg	x5
AN208150CC	AN208150CC		Fall arrester with energy absorber in braided rope Ø 10.5 mm. Thimble loops.		1 x AM002		0,8 kg	

AN218RCDD



AN208RCD



Article	Ref./Colours	Standard	Description	Connector 1	Connector 2	Sizes/Length	Weight	Quantity
AN218RCDD	AN218RCDD	CE EN355	Fall arrester with energy absorber in double braided rope Ø 12 mm (Y), adjustable by means of two gear rings on the rope.	1 x AM002	2 x AM022	1,30 to 2 m	2,0 kg	x5
AN208RCD	AN208RCD		Fall arrester energy absorber in braided rope Ø12 mm, simple and adjustable by means of a gear ring on the rope.		1 x AM022		1,3 kg	



FALL ARRESTERS

ANSI523



Reduced resting length, limits discomfort to the operator and the risk of stumbling.

Protective sheath.

Article	Ref./Colours	Standard	Description	Sizes/Length	Weight	Quantity
ANSI523	ANSI523	ANSI Z359.13	Fall arrester with energy absorber having single extensible webbing lanyard. Connectors - 21mm opening double snap hook and 65mm opening scaffolding hook.	1.8m	2,5 kg	x10

ANSI537



Protective sheath.

Reduced resting length, limits discomfort to the operator and the risk of stumbling.

ANSI561



Spliced protection.

Protective sheath.

Article	Ref./Colours	Standard	Description	Sizes/Length	Weight	Quantity
ANSI537	ANSI537	ANSI Z359.13	Fall arrester with energy absorber having double extensible webbing lanyard. Connectors - 21mm opening double snap hook and two 65mm opening scaffolding hooks.	1.8m	2,5 kg	x10
ANSI561	ANSI561	ANSI Z359.3	Adjustable rope lanyard Ø 14mm with 15mm and 21mm opening connectors.	2m	1,2 kg	

ENERGY ABSORBING LANYARDS

ANSI560



Reduced resting length, limits discomfort to the operator and the risk of stumbling.

kevlar material

Article	Ref./Colours	Standard	Description	Sizes/Length		
ANSI560	ANSI560	ANSI Z359.13	KEVLAR fall arrester with energy absorber with double Lanyard and Connectors. 21mm opening double snap hook and two 62mm opening scaffolding hooks	1.8m	2,5 kg	x10

ANSI557



Reduced resting length, limits discomfort to the operator and the risk of stumbling.

Dielectric connectors

Article	Ref./Colours	Standard	Description	Sizes/Length		
ANSI557	ANSI557	ANSI Z359.1	Di-electric fall arrester with energy absorber having single extensible webbing lanyard. Connector - one 65mm opening scaffolding hook.	Standard	1,3 kg	x10



FALL ARRESTERS

AN209



Protected eyes

100% polyester protective cover

Article	Ref./Colours	Standard	Description	Connector 1	Connector 2	Sizes/Length		
AN209CD	AN209	CE EN355	Fall arrester with energy absorber on single webbing lanyard. Webbing width - 27mm. Energy dissipater protected by a textile sheath.	1 x AM002	1 x AM022	1.1 to 2m	0,97 kg	x5
AN209BD				1 x AM025	1 x AM022		0,89 kg	
AN209AD				1 x AM010	1 x AM022		1,035 kg	

AN219



Protected eyes

100% polyester protective cover

Article	Ref./Colours	Standard	Description	Connector 1	Connector 2	Sizes/Length		
AN219ADD	AN219	CE EN355	Fall arrester with energy absorber on double webbing lanyard. Webbing width - 27mm. Energy dissipater protected by a textile sheath.	1 x AM010	2 x AM022	1.1 to 2m	1,6 kg	x5
AN219BDD				1 x AM025	2 x AM022		1,47 kg	
AN219CDD				1 x AM002	2 x AM022		1,55 kg	

ENERGY ABSORBING LANYARDS

AN208



Protected eyes

100% polyester protective cover

Article	Ref./Colours	Standard	Description	Connector 1	Connector 2	Sizes/Length	Person	Box	
AN208200CD	AN208	CE EN355	Fall arrester with energy absorber on single braided rope lanyard of diameter 10.5mm. Energy dissipater protected by a textile sheath.	1 x	1 x	2.0m	1,24 kg	x5	
AN208200AD				1 x	1 x				1,3 kg
AN208200BD				1 x	1 x				1,7 kg

AN218



Protected eyes

100% polyester protective cover

Article	Ref./Colours	Standard	Description	Connector 1	Connector 2	Sizes/Length	Person	Box	
AN218200CDD	AN218	CE EN355	Fall arrester with energy absorber on double braided rope lanyard of diameter 10.5mm. Energy dissipater protected by a textile sheath.	1 x	2 x	2.0m	2,1 kg	x5	
AN218200ADD				1 x	2 x				2,15 kg
AN218200BDD				1 x	2 x				2,0 kg







FALL ARRESTERS

AN201200AD



AN201200CD







Article	Ref./Colours	Standard	Description	Connector 1	Connector 2	Sizes/Length	Weight	Quantity
AN201200AD	AN201200AD	CE EN355	Fall arrester with energy absorber in stranded rope Ø 12 mm. Thimble loops.	1 x 	1 x 	2 m	0,91 kg	x5
AN201200CD	AN201200CD			1 x 	1 x 		0,84 kg	

AN211200ADD



AN211200CDD



Article	Ref./Colours	Standard	Description	Connector 1	Connector 2	Sizes/Length	Weight	Quantity
AN211200ADD	AN211200ADD	CE EN355	Fall arrester with energy absorber in stranded rope (Y) Ø 12 mm. Thimble loops.	1 x 	1 x 	2 m	1,6 kg	x5
AN211200CDD	AN211200CDD			1 x 	1 x 		1,52 kg	

ENERGY ABSORBING LANYARDS

AN203200AD



AN203200CD



Article	Ref./Colours	Standard	Description	Connector 1	Connector 2	Sizes/ Length	Weight	Quantity
AN203200AD	AN203200AD	CE EN355	Fall arrester with energy absorber in lanyard webbing. Thimble loops.	1 x	1 x	2 m	0,7 kg	x5
AN203200CD	AN203200CD			1 x	1 x		1,1 kg	

AN213200ADD



AN213200CDD



Article	Ref./Colours	Standard	Description	Connector 1	Connector 2	Sizes/ Length	Weight	Quantity
AN213200ADD	AN213200ADD	CE EN355	Fall arrester with energy absorber in double lanyard webbing (Y). Thimble loops.	1 x	1 x	2 m	1,6 kg	x5
AN213200CDD	AN213200CDD			1 x	1 x		1,54 kg	



FALL ARRESTERS



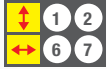







PROTECTOR TETRA



2 integrated carrying handles

To use the self retractable fall arrester certified for horizontal use, you have to pair the cable with the L0030 lanyard (page 53)



Article	Ref./Colours	Standard	Description	Connector 1	Sizes/Length	Weight	Quantity		
PROTECTOR TETRA	AN141F	EN360 + Intensive use + horizontal certification	Self retractable fall arrester with webbing with energy absorber. ABS case. Fall indicator. Inertia locking system.	1 x  AM021	6 m	5,3 kg	x1		
	AN141T			1 x  AM016					
	AN142F			1 x  AM021	8 m	5,4 kg			
	AN142T			1 x  AM016					
	AN152F		EN360 + Intensive use + horizontal certification	Self retractable fall arrester with webbing with energy absorber. ABS case. Fall indicator. Inertia locking system.	1 x  AM020	6 m	5,6 kg	x1	
	AN152T				1 x  AM016				
	AN153F				Self retractable fall arrester with galvanised steel cable with integrated energy absorber. ABS case. Fall indicator. Inertia locking system.	1 x  AM020	10 m		5,8 kg
	AN153T					1 x  AM016			
	AN154F					1 x  AM020	15 m		6,5 kg
	AN154T					1 x  AM016			

PROTECTOR METAL



Metal casing

Fall Indicator

Article	Ref./Colours	Standard	Description	Connector 1	Sizes/Length	Weight	Box
PROTECTOR METAL	AN115F	CE EN360	Self retractable fall arrester with galvanised steel cable with integrated energy absorber. Steel case. Fall indicator. Inertia locking system.	1 x AM020	20 m	9 kg	x1
	AN115T			1 x AM016			
	AN116F			1 x AM020	25 m	10 kg	
	AN116T			1 x AM016			
	AN11730F			1 x AM020	30 m	11 kg	
	AN11730T			1 x AM016			

PROTECTOR STAINLESS STEEL



Metal case

Stainless steel cable

Fall Indicator

Article	Ref./Colours	Standard	Description	Connector 1	Sizes/Length	Weight	Box
PROTECTOR STAINLESS STEEL	AN11010F	CE EN360	Self retractable fall arrester with Ø 5 mm stainless steel cable with integrated energy absorber. Metal case. Inertia locking system.	1 x AM020	10 m	9,4 kg	x1
	AN11010T			1 x AM016			
	AN11023F			1 x AM020	23 m		
	AN11023T			1 x AM016			



FALL ARRESTERS

PROTECTOR ELEVATOR



Integrated carrying handle

Up / down function valve rescue winch

Non return system



The rescue winch enables the evacuation of a person from above or below

Article	Ref./Colours	Standard	Description	Connector 1	Sizes/Length	Weight	Volume
PROTECTOR ELEVATOR	TR007F	CE EN360 EN1496 class B	Self retractable fall arrester in steel cable with removable rescue winch. Steel case. Inertia locking system. Energy absorber	1 x AM020	20 m	14,9 kg	x1
	TR007T			1 x AM016			
	TR01730F			1 x AM020	30 m	18,9 kg	
	TR01730T			1 x AM016			

MINIBLOC AN102



FIXBLOC AN105



Article	Ref./Colours	Standard	Description	Connector 1	Connector 2	Sizes/Length	Weight	Volume
FIXBLOC	AN105	EN360	Self retractable fall arrester with 46 mm strap with energy absorber. Protection case. 1 carabiner AM002	1 x AM002		1.50 m	0,9 kg	X5
MINIBLOC	AN102A	EN360	Self retractable fall arrester with strap. ABS case. Fall indicator. Inertia locking system.	1 x AM002	1 x AM010	2.5m	1,1 kg	
MINIBLOC	AN102AD	EN360		1 x AM022	1 x AM010			

RETRACTABLE FALL ARRESTERS

Most of our products have been tested with a mass constraint greater than 40% to 50% of the normative requirements (140 kg or 150 kg). Find this information in the technical specifications of our products.

PROTECTOR LOAD



LOAD SELF RETRACTABLE FALL ARRESTER

Intensive use

Composite material housing with high strength ABS

Inertia locking system

Integrated energy absorber

2 integrated carrying handles



Steel case

1 integrated carrying handle



Article	Ref./Colours	Standard	Description	Sizes/ Length			
PROTECTOR LOAD	AN517	CE Machi- nery Directive		Load fall arrester in galvanized cable Ø 4 mm to secure all moving loads under 250 kg.	10 m	5,1 kg	x1
	AN518			Load fall arrester in galvanized cable Ø 4 mm to secure all moving loads under 250 kg.	15 m	5,9 kg	
	AN521			Load fall arrester in galvanized cable Ø 4.5 mm to secure all moving loads under 300 kg.	10 m	5,7 kg	
	AN510			Load fall arrester in galvanized cable Ø 4 mm to secure all moving loads under 100 kg.		6,0 kg	
	AN530			Load fall arrester in galvanized cable Ø 6 mm to secure all moving loads under 500 kg.	12 m	11 kg	



CAMELEON

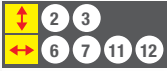

AN066A



AN066



AN006



TC009



AN410
AN420
AN430
AN401

FALL ARRESTER ON FLEXIBLE ANCHORAGE LINE



Fall indicator and non-inverting device

The extension tab allows more mobility

Opening with one hand



Double safety opening: installation without disconnecting from the harness

Article	Ref./Colours	Standard	Description	Connector 1	Sizes/Length		
CAMELEON AN066A	AN066A	EN353-2 EN358 EN12841 type A and type B CE	3 multi function products in 1: Sliding fall arrester on braided rope anchorage line \varnothing 10.5 mm - Stopper on rope - Rope Adjuster equipped with an extension tab with energy absorber and an AM002 carabiner. The fall arrest device slides on its anchorage line and in case of a fall, automatically locks and stops the fall of the user. The rope's adjusting device used in the safety bracket (type A) accompanies the user during his changes of position and locks under the action of a static or dynamic load. The ascension device on its work support, locks under the action of a load in one direction and slides freely in the opposite direction (type B). The positioning device allows adjustment of the distance between the operator (with work positioning belt) and the structure.	1 x		0,4 kg	
CAMELEON AN066	AN066		3 multi function products in 1: Sliding fall arrester on braided rope anchorage line \varnothing 10.5 mm - Stopper on rope - Rope Adjuster with a carabiner AM002. The fall arrest device slides on its anchorage line and in case of a fall, automatically locks and stops the fall of the user. The rope's adjusting device used in the safety bracket (type A) accompanies the user during his changes of position and locks under the action of a static or dynamic load. The ascension device on its work support, locks under the action of a load in one direction and slides freely in the opposite direction (type B). The positioning device allows adjustment of the distance between the operator (with work positioning belt) and the structure.	AM002		0,3 kg	x5
AN410	AN410	EN353-2 EN12841	Anchorage line in braided rope \varnothing 10.5 mm for CAMELEON®. 1 loop sewn thimble. Equipped with an AN006 counterweight and an AM002 connector.	1 x	10 m	1,4 kg	
AN420	AN420				20 m	1,9 kg	
AN430	AN430				30 m	2,4 kg	
AN401	AN401				per meter-> 30 m		x1
AN006	AN006		Counterweight for anchorage line \varnothing 8-18 mm in black rubber. Weight 400 g.			0,4 kg	x30
TC009	TC009		Braided rope \varnothing 10.5 mm - Length on request.				



FALL ARRESTERS

ASCORD AN060



Non-inverting device

Energy absorber with fall indicator

AN315



Article	Ref./Colours	Standard	Description	Connector 1	Sizes/ Length	Weight	Quantity
ASCORD AN060	AN060	CE EN353-2	Fall arrester sliding on anchorage line stranded rope Ø 14 mm (rope sold separately). Opening type fall arrester equipped with automatic locking, non-inverting device, energy absorber with fall indicator. 1 carabiner AM002.	1 x  AM002		0,7 kg	x5
AN315	AN315		Anchorage line stranded rope Ø 14 mm for ASCORD®. End spliced with thimble loop.		10 m	1,5 kg	x10
AN317	AN317				20 m	2,8 kg	x5
AN319	AN319				30 m	4,1 kg	
AN013	AN013					per meter > 30 m	

FALL ARRESTER ON FLEXIBLE ANCHORAGE LINE

FENNEC

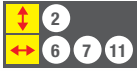

Recommended accessory for the proper use of this product: 1 connector AM002

AN003



Article	Ref./Colours	Standard	Description	Sizes/ Length	Weight	Quantity
FENNEC	AN06310	CE EN353-2	Sliding non opening fall arrester set with fall indicator on stranded rope anchorage line Ø 12 mm. Wear indicator. 1 loop spliced on high end.	10 m	1,3 kg	x10
	AN06320			20 m	2,2 kg	x5
	AN06330			30 m	3,0 kg	
	AN06300		Sliding non opening fall arrester with fall indicator.		3,7 kg	x10
AN003	AN003	CE EN353-2	anchorage line stranded rope Ø 12 mm. Wear indicator. Longer by more than 30 m. Rope equipped with an AN06300.	per meter > 30 m		x1



FALL ARRESTERS



AN801

AN802

AN024

AN025

AN801



Rectangular attachments

$L1 \leq 160 \text{ mm}$
 $L2 \leq 94 \text{ mm}$

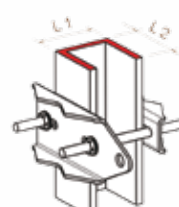
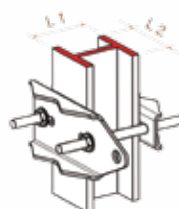
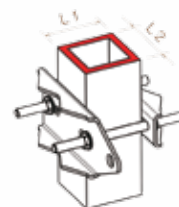

L-shaped attachments

$L1 \leq 160 \text{ mm}$
 $L2 \leq 94 \text{ mm}$

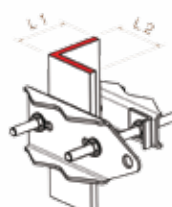

T-shaped attachments

$L1 \leq 160 \text{ mm}$
 $L2 \leq 94 \text{ mm}$

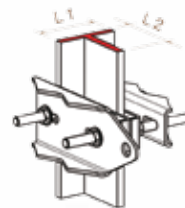

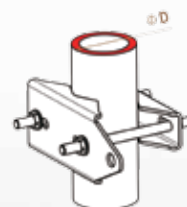

Tubular attachments

$\emptyset \leq 94 \text{ mm}$



ASCAB AN070



Article	Ref./Colours	Standard	Description	Sizes/ Length		
AN801	AN801	CE EN795-A	Top attachment (EN795-A), lower attachment and tensioner system in stainless steel with universal anchorage.		4 kg	x6
AN802	AN802		Intermediary attachment in inox steel with universal anchorage. Recommended at least every 8 m.		1.5 kg	x12
AN024	AN024	CE EN353-1 EN353-2	1 meter anchorage line cable for ASCAB 3® in stainless steel. 1 thimble sleeve loop.			x1
AN025	AN025		Additional meter of anchorage line cable for ASCAB 3®.			
ASCAB AN070	AN070	CE EN353-1 EN353-2	Sliding opening fall arrester on anchorage line in cable Ø 8 mm with self-locking, non-inverter device, extension tab with energy absorber. 1 carabiner AM002.		1 kg	x5
LDW04	LDW04		Ready to use vertical lifeline kit. For use by one person on a ladder, upright or rungs resistant to at least a load of 10 kN.	4 m	5 kg	x1
LDW06	LDW06			6 m	6 kg	
LDW08	LDW08			8 m	7 kg	
LDW10	LDW10			10 m	8 kg	
LDW12	LDW12			12 m	9 kg	



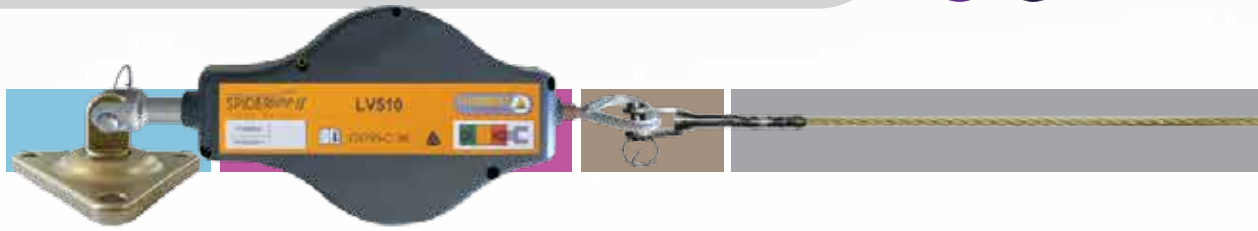

End pieces

	LV504 End anchorage - 3 fastening holes
	LV505 End anchorage - 1 fastening hole
	LV506 End anchorage - 1 fastening hole with threaded rod
	LV521 End bollard counter plate
	LV522 End bollard

Absorber

	LV510 Energy dissipater with fall indicator and power indicator
--	---------------------------------------------------------------------------

Various

	LV515 Fork end to swage for cable - 8 mm
	LV516 Tensioner to crimp
	LV527 Lead to seal the SPIDERLINE II lifeline

Various

	LV555 SPIDERLINE II Sample case
	LV057 Sign post

Cable

	LV040 Cable
	LV531 Cable reel - 200 m
	LV532 Cable reel - 1,000 m
	LV514 Workforce cable crimping
	LV528 Crimping machine
	LV529
	LV530

SPIDERLINE II®

Article	Ref./Colours	Standard	Description	Sizes/Length		
SPIDERLINE II	SPIDERLINE	CE EN795-C	Permanent horizontal lifeline in cable Ø 8 mm. Stainless steel components. Suitable for all media types, locations and materials: floors, walls, ceilings, inside or outside. For more information, please contact us.			
LDVH04	LDVH04		Ready to use vertical lifeline kit. For use by one person on a ladder, upright or rungs resistant to at least a load of 10 kN.	4 m	4,4 kg	x1
LDVH06	LDVH06			6 m	4,9 kg	
LDVH08	LDVH08			8 m	5,4 kg	
LDVH10	LDVH10			10 m	5,9 kg	
LDVH12	LDVH12			12 m	6,4 kg	

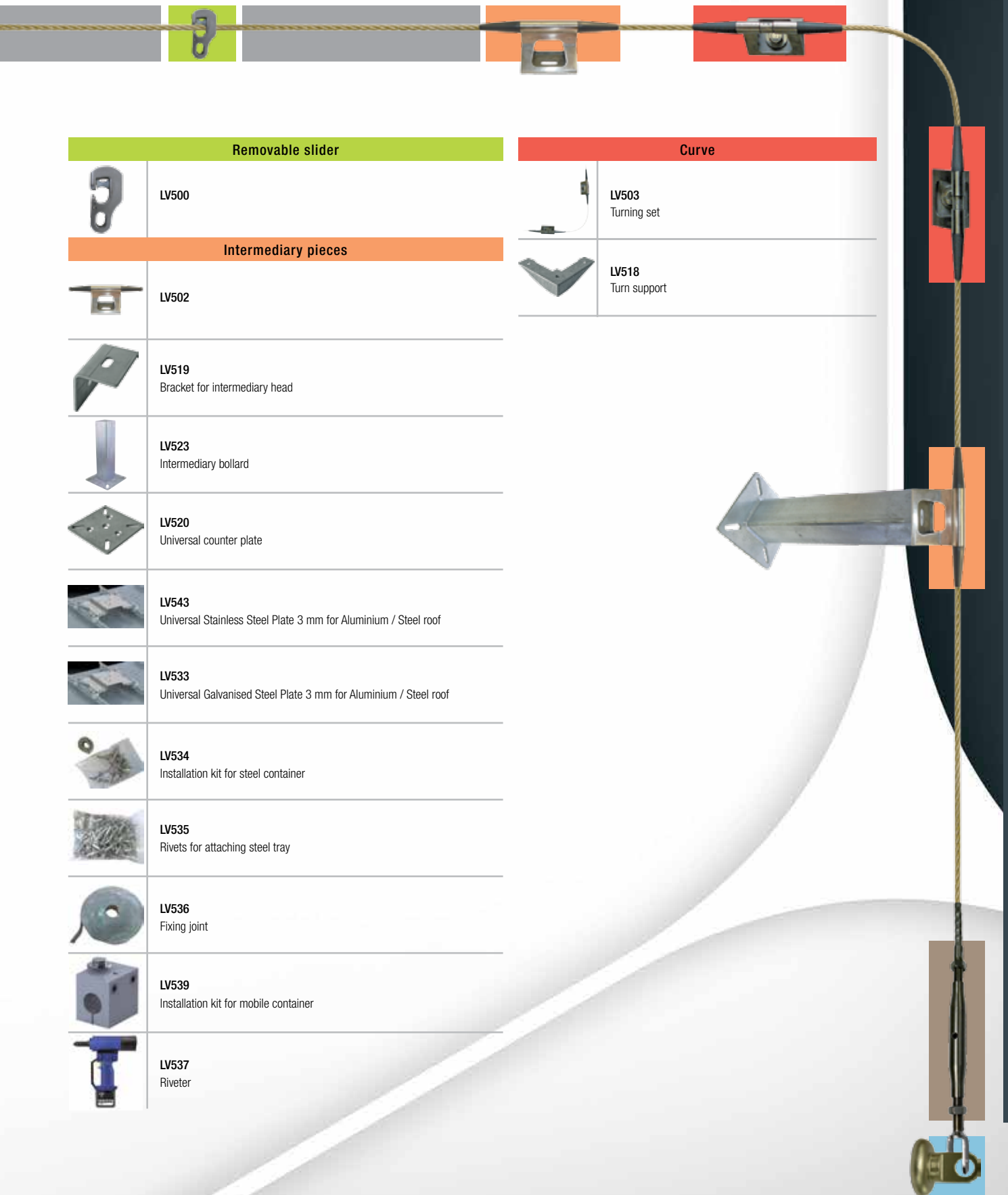

Removable slider



LV500

Intermediary pieces



LV502



LV519
Bracket for intermediary head



LV523
Intermediary bollard



LV520
Universal counter plate



LV543
Universal Stainless Steel Plate 3 mm for Aluminium / Steel roof



LV533
Universal Galvanised Steel Plate 3 mm for Aluminium / Steel roof



LV534
Installation kit for steel container



LV535
Rivets for attaching steel tray



LV536
Fixing joint



LV539
Installation kit for mobile container



LV537
Riveter

Curve



LV503
Turning set



LV518
Turn support



ANCHORAGE

SPEEDLINE LV201



Protection of leather buckles

Strap width 35 mm

Article	Ref./Colours	Standard	Description	Sizes/Length	Person	Box
SPEEDLINE LV201	LV201	CE EN795-B	Temporary horizontal lifeline with certified strap for 2 people. Adjustment of the length and the tension with a ratchet tensioner. Equipped with 2 carabiners AM002. Bag for storage and transport.	2.50 to 20 m	3,3 kg	x1

IPN LV130



DAYAK LV120G



Article	Ref./Colours	Standard	Description	Person	Box
IPN LV130	LV130	CE EN795-B	A transportable interim anchorage device with aluminium alloy wheels. It can be attached to beams of width 76 to 255 mm.	4 kg	x1
DAYAK LV120G	LV120G		Transportable anchorage point, galvanized steel, for door frame or window of 63 to 123 cm. Adjustable with clamping screw.	7 kg	

LV100



Easy Installation



LV102100



Article	Ref./Colours	Standard	Description	Sizes/ Length	Person	Box	
LV100	LV100	CE EN795-A	Stainless steel anchorage mounting plate with screws Ø 12 mm.		0,05 kg	x10	
LV102100	LV102100		EN795-B	Anchorage ring with high tenacity polyester strap. Width 45 mm. End loop with shrinkage and steel anchor D.	1 m		0,29 kg
LV102150	LV102150				1,50 m		0,30 kg

LV105



AM007



Studied for structures with sharp corners



Article	Ref./Colours	Standard	Description	Sizes/ Length	Person	Box
LV105	LV105	CE EN795-A	Anchorage with stainless steel eye Ø 12 mm. Overall length 140 mm. Rod length (under flange) 100 mm. Thread length 80 mm.		0,12 kg	x10
AM007	AM007		EN354 EN795-B	Sling anchor in galvanized steel cable Ø 8 mm. Protective sheath. 2 thimble ferrule loops.	1 m	





FALL ARRESTERS

LO147150CDD



LO147150





Article	Ref./Colours	Standard	Description	Connector 1	Connector 2	Sizes/Length	Weight	Quantity
LO147150CDD	LO147150CDD	CE EN354	Double lanyard in braided rope Ø 10.5 mm. 2 sewn loop ends.	1 x 	2 x 	1.50 m	1,45 kg	x5
LO147150	LO147150			AM002	AM022		0,30 kg	x15

LO047150AD



LO047100



Article	Ref./Colours	Standard	Description	Connector 1	Connector 2	Sizes/Length	Weight	Quantity
LO047150AD	LO047150AD	CE EN354	Lanyard in braided rope Ø 10.5 mm. 2 sewn loop ends.	1 x 	1 x 	1.50 m	0,83 kg	x15
LO047100	LO047100					1 m	0,14 kg	
LO047150	LO047150					1.50 m	0,16 kg	
LO045200	LO045200					2 m	0,18 kg	

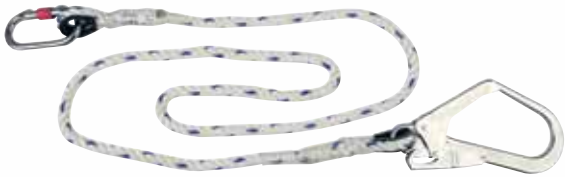

LANYARDS

LO007150CD



LO007100



Article	Ref./Colours	Standard	Description	Connector 1	Connector 2	Sizes/Length	Weight	Quantity
L0007150CD	L0007150CD	CE EN354	Single lanyard in stranded rope Ø 12 mm. 2 thimble loops.	1 x  AM002	1 x  AM022	1.50 m	0,87 kg	x15
L0007100	L0007100R					1 m	0,18 kg	
L0007150	L0007150					1.50 m	0,22 kg	
L0005200	L0005					2 m	0,26 kg	

LO030



Article	Ref./Colours	Standard	Description	Sizes/Length	Weight	Quantity
L0030	L0030	CE EN354 EN795-B	Lanyard and anchorage point in tubular webbing. 2 sewn loops. Width 25 mm.	2 m	0,13 kg	x15
L0031	L0031			1.50 m	0,10 kg	
L0032	L0032			1 m	0,07 kg	



















CONNECTORS















Article	Ref./Colours	Standard	Description		
AM009 	AM009	CE EN362	Quick docking in stainless steel. Large aperture 150 mm. Eye hook. R > 22 kN. 	0,38 kg	x20
AM022 	AM022	CE EN362	Automatic hook lock in galvanized steel. Large aperture 55 mm. Eye hook. R > 20 kN. 	0,50 kg	x20
AM027 	AM027	CE EN362	Automatic locking carabiner in light alloy. Large aperture 58 mm. Sliding ring. Eye hook opening with latch. 	0,24 kg	x20
AM030 	AM030	CE EN362 EN12275	Automatically locking hook in aluminium alloy. Opening 25 mm. 	0,13 kg	x20
AM018 	AM018	CE EN362 EN12275	Carabiner with 1/4 turn automatic lock in steel. Opening 17 mm. R > 25 kN. 	0,20 kg	x20

Article	Ref./Colours	Standard	Description		
AM020 	AM020	CE EN362	Auto connector with swivel in light alloy with fall indicator, automatic closing and locking, equipped with an opening fork, 11 mm wide.	0,13 kg	x5
	AM021		Auto connector with swivel in light alloy with fall indicator, automatic closing and locking, equipped with an opening fork, 22 mm wide. 		
AM021					
AC001 	AC001	CE EN354	Swivel with aluminium fall indicator, equipped with a non opening cap, width 11 mm and an opening cap, width 11 mm.	0,06 kg	x5
	AC002		Swivel with aluminium fall indicator, equipped with a non opening cap, width 22 mm and an opening cap, width 22 mm. 		
AC002					
AM006 	AM006	CE EN362	Triangular snap shackle with galvanized steel screw. Opening 8 mm. 	0,09 kg	x20
AM002 	AM002	CE EN362	Screw lock carabiner in galvanized steel. Opening 17 mm. R> 23 kN. 	0,22 kg	x20
AM025 	AM025	CE EN362	Automatic locking carabiner in light alloy. Opening 22 mm. Ring 1/4 turn. R> 25 kN 	0,09 kg	x20
AM010 	AM010	CE EN362	Automatic hook lock in steel. Eye hook. Opening 16 mm. R> 23 kN. 	0,23 kg	x20



ROPE ACCESS

Article	Ref./Colours	Standard	Description		
TC001 	TC001	CE EN567	Ventral opening blocker type in aluminium alloy. Works on braided rope Ø 8 to 13 mm. 	0,16 kg	x10
TC002 	TC002	CE EN567	Right hand ascension handle in aluminium alloy. Works on braided rope Ø 8 to 13 mm. 	0,24 kg	x10
TC003 	TC003		Left hand ascension handle in aluminium alloy. Works on braided rope Ø 8 to 13 mm. 		
DESCORD TC006 	TC006	CE EN341 Class A EN12841 Class C	Self locking descender with double security (anti-panic system) in aluminium. Intended for works on braided rope Ø 9 à 12 mm. 	0,36 kg	x5
TC004 	TC004		Figure of eight in aluminium alloy. Works on braided rope Ø 9 to 12 mm. 	0,13 kg	x20
TC044 	TC044		Safety figure of eight in aluminium alloy. Works on braided rope Ø 9 to 16 mm. 	0,26 kg	x20
TC040 	TC040	CE EN354	Double swivel on ball bearing. 	0,16 kg	x20

Article	Ref./Colours	Standard	Description		
TC005 	TC005	CE EN12278	Oscillating pulley flanges in aluminium alloy. Intended for works on braided rope less than 16 mm diam. 	0,25 kg	x10
TC015 	TC015	CE EN12278	Double pulley with oscillating flanges in aluminium alloy for braided rope less than 16 mm diameter. 	0,43 kg	x10
TC025 	TC025	CE EN12278	Double aluminium alloy pulley on ball bearings, designed for zip lines (less than 13 mm diameter) and cables (less than 12 mm diameter). 	0,28 kg	x10
TC016 	TC016	CE EN12278	Mini pulley in aluminium alloy for works on braided rope less than Ø 11 mm diam and cable less than Ø 12 mm. 	0,14 kg	x10
TC012 	TC012		Mono stirrup adjustable strap 25 mm from 90 to 120 cm . Pedal ascent. To pair with TC002 or TC003. 	0,20 kg	x5
TC029 	TC029		Opening rope protection 35 cm. Velcro tape closure. Scalable length by adding elements. 	0,20 kg	x10



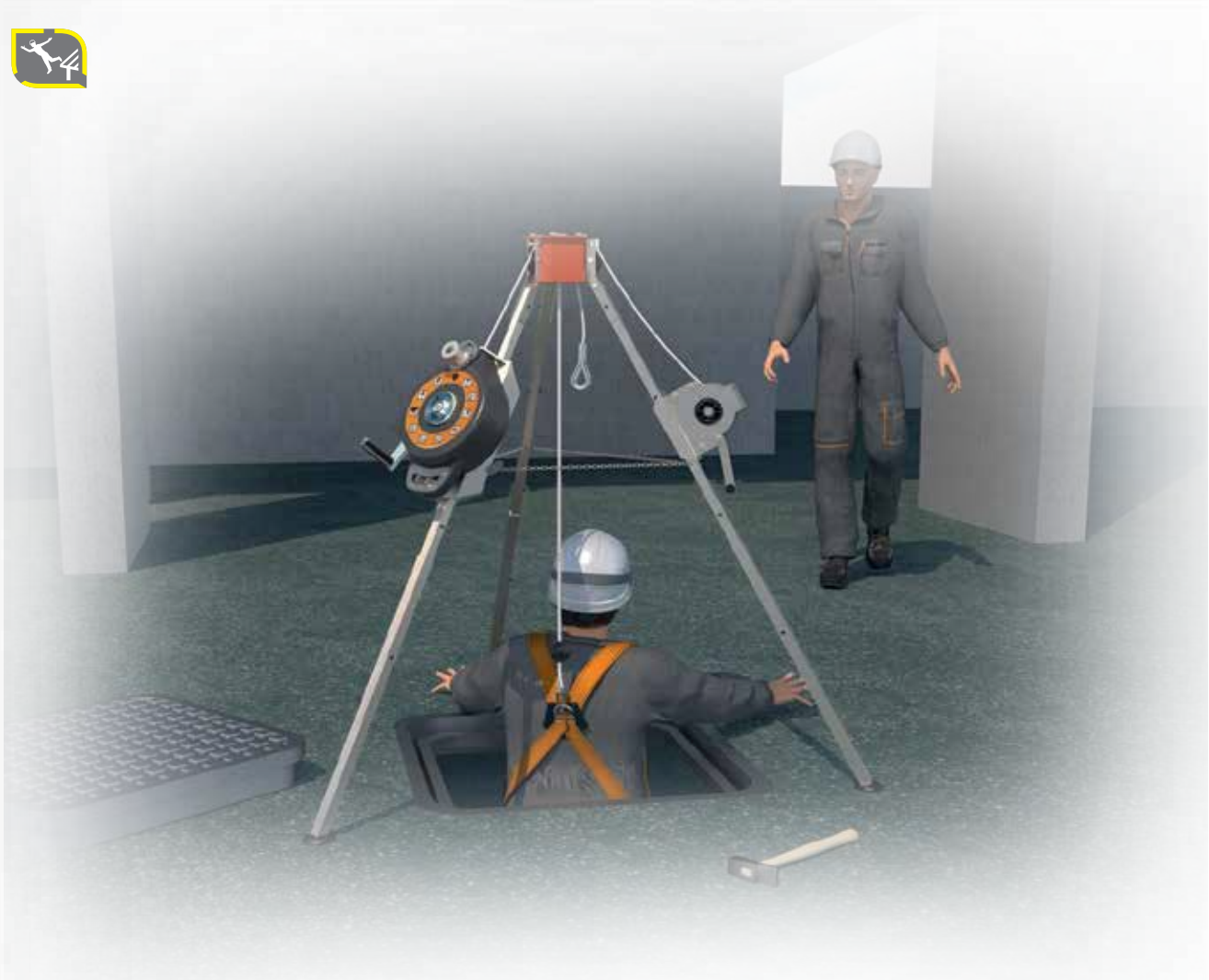

Article	Ref./Colours	Standard	Description	Connector 1	Sizes/ Length		
TR020	TR020	EN795-B	Telescopic tripod in galvanized steel. Adjustable height from 1.45 m to 2.15 m. Maximum wheelbase of 1.50 m on the ground. 1 central anchorage ring for a fall arrest. Able to attach an adjustment board TR101 or TR102 for a self retracting fall arrest.			20 kg	x1
TR022	TR022		Telescopic tripod in galvanized steel. Adjustable height from 1.45 m to 2.15 m. Maximum wheelbase of 1.50 m on the ground. 1 central anchorage ring for a fall arrest. Equipped with two adjustable plates for a self retracting fall arrest.		26 kg		
TR003C	TR003C	Machinery Directive EN292	Manual winch in galvanized cable. Length 20 m. Non-return system. Folding handle, load capacity 300 kg.		20 m	7,8 kg	
TR003K	TR003K		Manual winch in galvanized cable. Length 30 m. Non-return system. Folding handle.		30 m	8,1 kg	
PROTECTOR ELEVATOR	TR007F	EN360 EN1496 class B	Self retractable fall arrester in steel cable with removable rescue winch. Steel case. Inertia locking system. Energy absorber	1 x AM020	20 m	14,9 kg	
	TR007T			1 x AM016			
	TR01730F			1 x AM020	30 m	18,9 kg	
	TR01730T			1 x AM016			
TR101	TR101		Bracket in galvanized steel for a self retractable fall arrester. To attach to a TR020 tripod.			3 kg	
TR102	TR102		Bracket in galvanized steel for winch. To attach to a TR020 tripod.				
TRBAG	TRBAG		Storage bag with wheels for tripod.			1,7 kg	x10

TR020

TR022

TR003C

TR003K



TR102

TR007F

TR007T

TR01730F

TR01730T



TR101

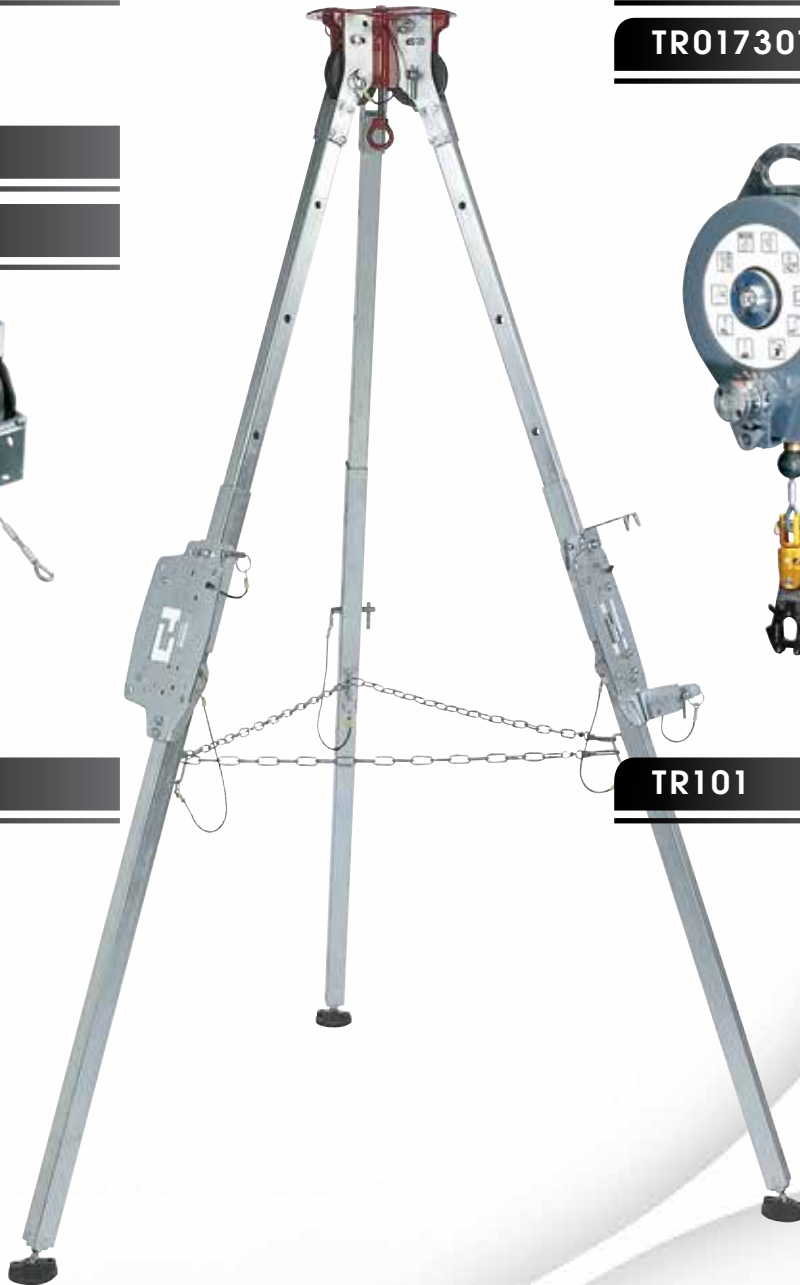

TRBAG



RESCUE

TC013



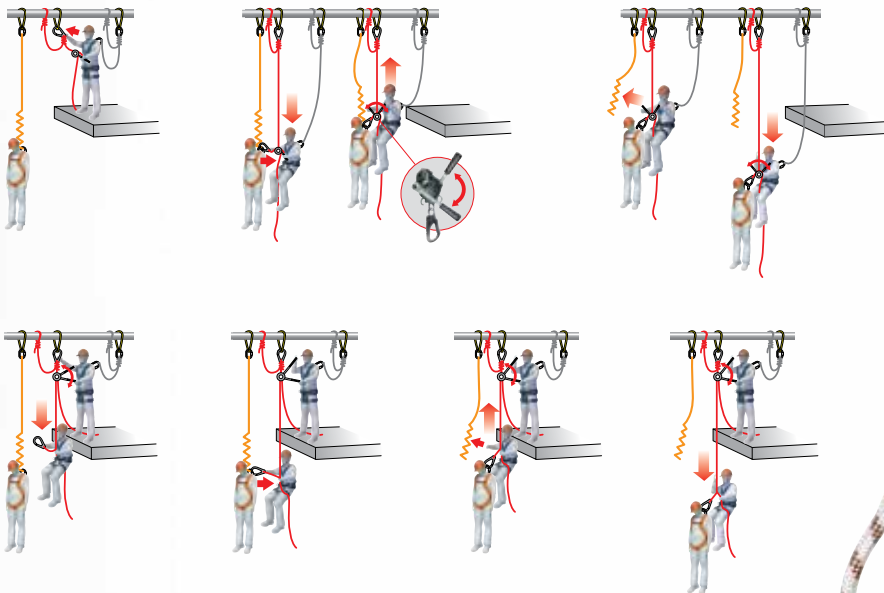

Usable by 1 or 2 rescuers.

Approved for 2 people



Equipped with a storage bag TC008



Article	Ref./Colours	Standard	Description	Sizes/Length		
TC013	TC013	 EN341 EN1496 Class A	Evacuation and rescue equipment. It enables multi to and for evacuations, to access a person, to recover and evacuate them. Suitable for 1 or 2 rescuers. Approved for 2 people. TC014 rope sold separately by the meter (length up to 160 m).		5 kg	x1
TC014	TC014		Braided rope Ø 9 mm for TC013. Sold by the meter, max length 160 m. Thimble loops.	per meter < 160 m		

TC102



Extra light and robust



TC103



Article	Ref./Colours	Standard	Description		
TC102	TC102	CE Directive 93/42/ CEE	Universal rescue stretcher sold with: Nylon rope along the perimeter 3 belts of 50 mm in nylon with quick release. Closed cell waterproof mattress. Pre-formed polyethylene footrest with adjustable position. in high-density polyethylene shell is attached to an aluminium frame	13,5 kg	x1
TC103	TC103		Sling system for vertical transport of stretchers (specially designed for TC102). Adjustable length. Equipped with 4 hooks.	2,1 kg	

TC022



TC019



Article	Ref./Colours	Standard	Description		
TC022	TC022	CE EN1498 Class B	Rapid evacuation triangle. Fits all body types with its 12 adjustment points.	1,1 kg	x1
TC019	TC019		Evacuation lot composed of: 50 m braided rope Ø 10.5 mm 1 double safety auto locking descender device TC006 1 anchor ring LV102150 2 connectors AM025 1 carrier bag TC008	7,1 kg	





GRANITE PEAK

GRANITE WIND



GRAPEJAFI

GRAWIJAFI



GRAPEBCFI

GRAWIBCFI



GRAPEBLFI

GRAWIBLFI



GRAWIORFI



GRAWIORFI



GRAWINO



BASGAMMA



JUGAMMA

Article	Ref./Colours	Standard	Description		
GRANITE WIND	GRAWIORFI Fluo red	EN397 MM -20°C +50°C	Ventilated ABS safety helmet. Mountain helmet style: without visor for the best vertical vision. Less encumbrance. Light. Polyamide harness: 3 textile bands with 8 fixing points. Thermofomed sweat band. Innovative adjustable ROTOR® system (patented); head sizes 53 to 63 cm. Sold with 3 point chin strap.	355 g	x10
	GRAWIBCFI Fluo white				
	GRAWIBLFI Fluo blue				
	GRAWICOFI Fluo orange				
	GRAWINO Black				
	GRAWIAFI Fluo yellow				
GRANITE PEAK	GRAPEJAFI Fluo yellow	EN397 MM 440VAC -20°C +50°C EN50365 CLASS 0	ABS safety helmet. Mountain helmet style: without visor for the best vertical vision. Less encumbrance. Light. Polyamide harness: 3 textile bands with 8 fixing points. Thermofomed sweat band. Innovative adjustable ROTOR® system (patented); head sizes 53 to 63 cm. Sold with 3 point chin strap. Specially designed for working at height. Electrical insulation up to 1 000 V.A.C. or 1 500 V.D.C.	350 g	
	GRAPEBCFI Fluo white				
	GRAPEBLFI Fluo blue				
BASGAMMA	BASGANO Black		Bag of 5 thermoformed sweat bands for GRANITE PEAK & WIND, BASEBALL DIAMOND, SUPER QUARTZ and QUARTZ UP safety helmets.		x20
JUGAMMA	JUGGANO Black		Bag of 5 chin straps with 3 fixing points. Safety-breaking system. Suitable for GRANITE PEAK and GRANITE WIND safety helmets.		



Polyamide harness : 3 textile bands with 8 fixing points
GRANITE PEAK - GRANITE WIND



Special system of fins which give protection against splashes and optimized surface ventilation



ROTOR® system (Patented) for easy use
GRANITE PEAK - GRANITE WIND



Thermoformed sweat band
GRANITE PEAK - GRANITE WIND



Removable chin strap with 3 fixing points
GRANITE PEAK - GRANITE WIND



FALL PROTECTION

EN795 : 1996 ► Anchorage devices

Element to which a personal protective equipment can be fastened.
(Standard under development)

CLASS A1 ► NON PPE

Consists of anchorage points designed to be fixed on vertical, horizontal and inclined surfaces (walls, columns, and lintels).

CLASS A2 ► NON PPE

Consists of anchorage points designed to be fixed on inclined roofs.

CLASS B ► PPE

Consists of mobile temporary anchorage devices.

CLASS C ► NON PPE

Consists of anchorage devices fitted with horizontal flexible anchorage lines 'life line' allowing inclination : 15°.

CLASS D ► NON PPE

Consists of anchorage devices fitted with horizontal rigid anchorage rails.

CLASS E ► PPE

Consists of dead weight anchors to be used on horizontal surfaces, allowing inclination : 5°.



OTHER STANDARDS

EN1498 ► RESCUE STRAP

Directive 94/9/EC for equipment intended for use in potentially explosive environments

EN13463-1 ► NON-ELECTRICAL EQUIPMENT FOR POTENTIALLY EXPLOSIVE ATMOSPHERES

basic method and requirements (risk analysis).

EN13463-5 ► NON-ELECTRICAL EQUIPMENT FOR POTENTIALLY EXPLOSIVE ATMOSPHERES

protection constructional safety "c" regarding the main mechanical devices: joints, bearings, gears, belts, clutch chains, brakes, coupling devices, conveyor belts

It sets out the requirements to be respected for the design and maintenance instructions.

It sets out the requirements and tests to be conducted according to the type of component.





THE CORRECT SELECTION OF FALL ARREST PRODUCTS GIVES PERFECT SAFETY

Fall arrest equipment includes different products which have to be adapted for each risk to ensure the necessary protection. These products (full body harness, fall arrester on anchorage line, work positioning systems, energy absorbers, self-retractable fall arrester, accessories) are governed by the Directive 89/686/EEC and the European standards on Personal Protective Equipment (PPE).

THE HARMONIZED EUROPEAN STANDARDS

All protective equipment against falls from a height are submit to European standards. You will find, below, a summed up presentation of every standard.

GENERAL STANDARDS

EN363 ► Fall arrest equipment

Set of personal protective equipment against falls from height, linked to one another and intended to stop a fall. A fall arrest equipment must contain at least a full body harness and a fall arrest equipment.

EN364 ► Test method

Describes the different test methods of the various PPE against falls from height, as well as the test equipment.

EN365 ► General requirements for the instructions for use and the marking

Description of the marking that must figure on the PPE against falls from height and of the information which must appear on the instructions for use.

SPECIFIC STANDARDS

EN361 ► Full body harness

Body securing device intended to stop falls. The full body harness can be made of straps, buckles and other elements; set and adjusted in a right way on the body of an individual to secure him during a fall and afterwards.

EN353-1 + CNB VG11.073 ► Mobile Fall Arrester On Rigid Anchorage Line

Equipment consisting of a mobile fall arrester with self-locking, integral with its rigid anchorage line (rail, cable...). An energy reducer can be built-in on the equipment.

EN353-2 ► Mobile fall arrester on flexible anchorage line

Equipment consisting of a mobile fall arrester with self-locking, integral with its flexible anchorage line (rope, cable...). An energy reducer (absorber) can be built-in in the equipment.

EN355 ► Energy absorber

Component of a fall arrest equipment, which guarantees the stop of a fall from a height in safety by reducing the impact of the shock. **WARNING:** If we associate a lanyard energy absorber, the total length of the entire device must not exceed 2 m.

EN360 ► Self-retractable fall

Fall arrester with self-locking device and a self-retractable system for the lanyard. An energy reducer (absorber) can be built-in in the equipment.

EN362 ► Connector

Connection element or equipment component. A connector can be karabiner or a snap hook.

EN354 ► Lanyards

Connection elements or equipment component. A lanyard can be in rope made of synthetic fibres, in metallic rope, in strap or in chain. Maximum length: 2m. **CAUTION:** A lanyard without energy absorber must not be used as a fall arrest equipment.

EN358 ► Work positioning system

A work positioning system consists of components (work positioning belt and lanyard) linked to one another to form a complete equipment.

EN813 ► Seat harnesses.

EN1891 ► Sheathed braided rope with a low coefficient of elongation (static ropes).

EN12841 ► Rope access system.

A rope device for work positioning.

EN1496 ► Rescue equipment

Rescue lifting devices.

EN567 ► Equipment for mountaineering and climbing

Safety requirements and test methods for blockers.

EN341 ► PPE against falls from height

Descending devices.





DELTAPLUS
YOUR SAFETY AT WORK

مركز البراغي والعدد
BOLTS & TOOLS CENTER **BTGO**